

TRU-CLOSE HEAVY DUTY HINGES ON PED GATE
1:4

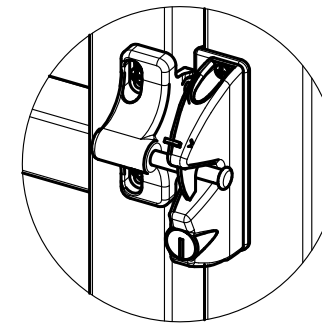

LOKKLATCH ON PED GATE
1:4

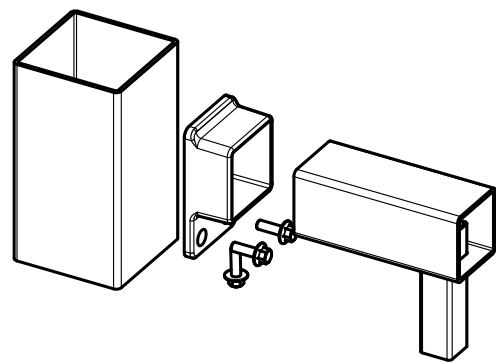

FIXED PANEL TO POST DETAIL
1:4

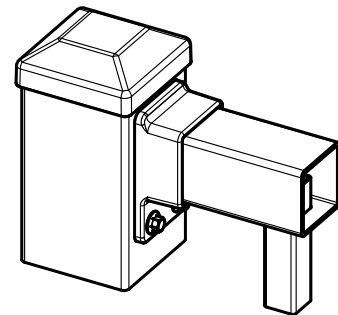

FIXED PANEL TO POST DETAIL
1:4

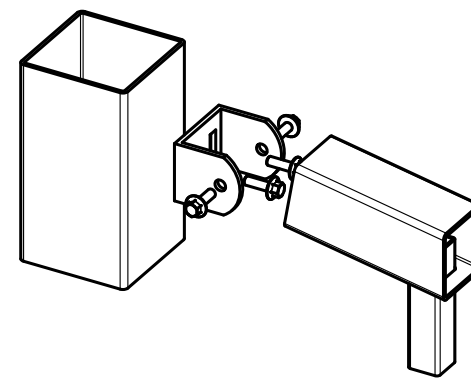

RAKING PANEL TO POST DETAIL
1:4

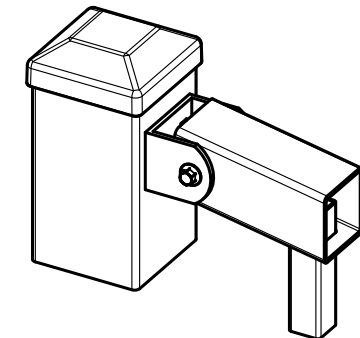

RAKING PANEL TO POST DETAIL
1:4

PANEL CODE	DESCRIPTION	BRACKET CODE	HEIGHT	WIDTH	PANEL RAKE	HORIZONTALS	VERTICALS	TUBE SPACINGS
UFASH18	ASSURE HEAVY DUTY FENCE PANEL	HBKT40	1800	2350	N/A	40X40X2 SHS	25X25X1.4 SHS	100 (125 CENTRES)
UFASHR18	ASSURE HEAVY DUTY RAKING FENCE PANEL	HBKTR40	1800	2350	20 DEGREES	40X40X2 SHS	25X25X1.4 SHS	100 (125 CENTRES)
SGASH18/12	ASSURE HEAVY DUTY PEDESTRIAN GATE	N/A	1800	1200	N/A	40X40X2 SHS	25X25X1.4 SHS	100 (125 CENTRES)



SIZE:	A3	SCALE:	1:25
DRAWING NO:	ASHD18 - SS	REVISION:	01
DATE ISSUED:	2023-02-21	SHEET:	1 OF 2

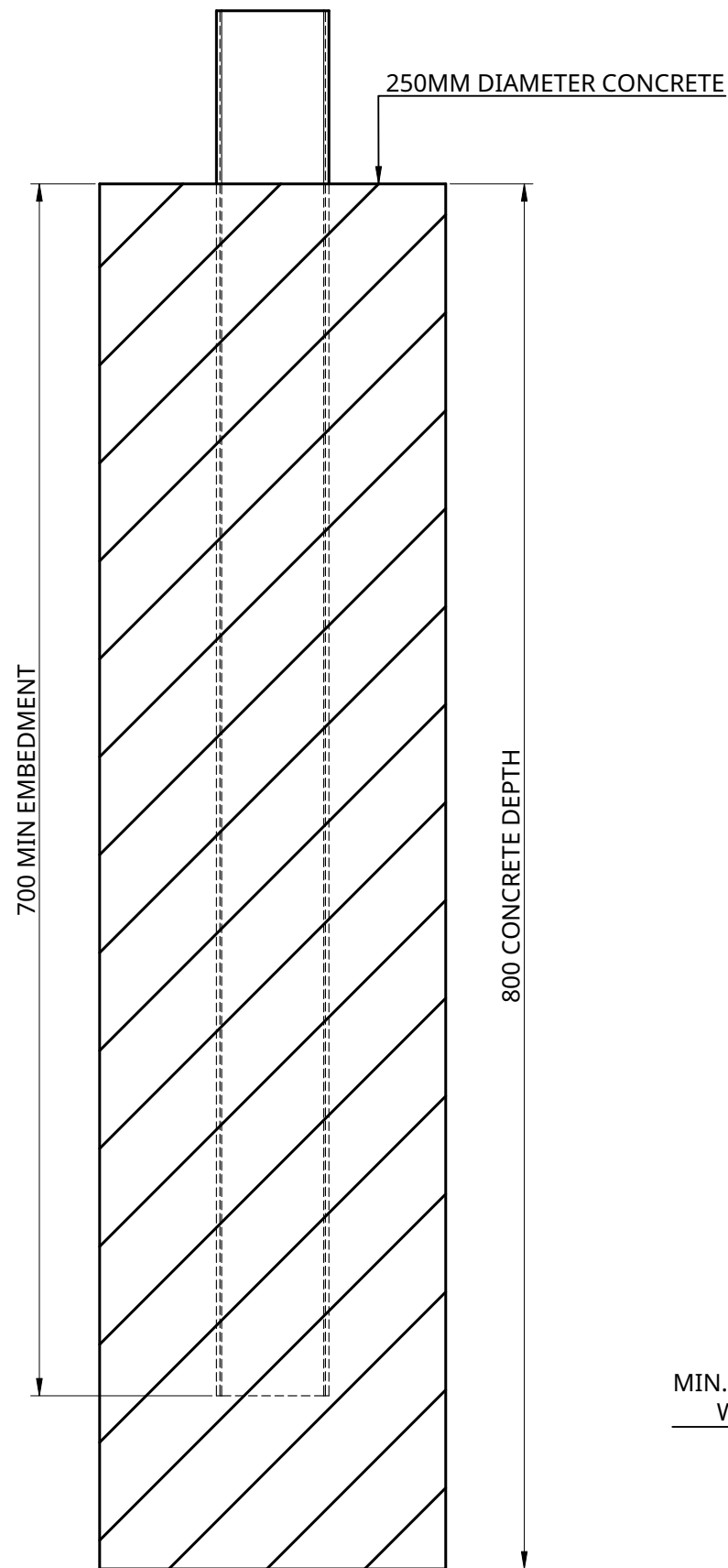

IN GROUND POST CONNECTION

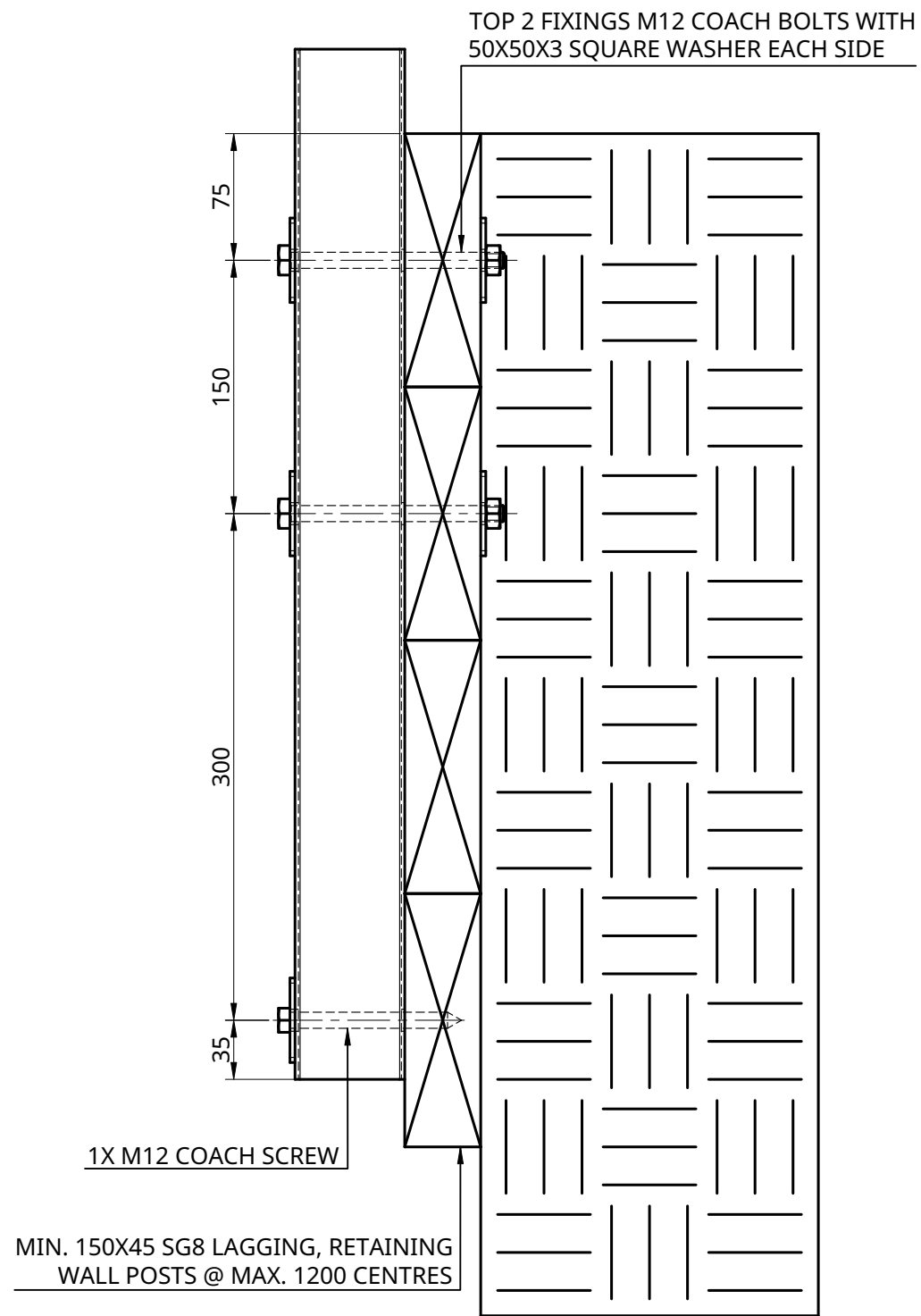

SIDE FIX TO TIMBER RETAINING WALL CONNECTION

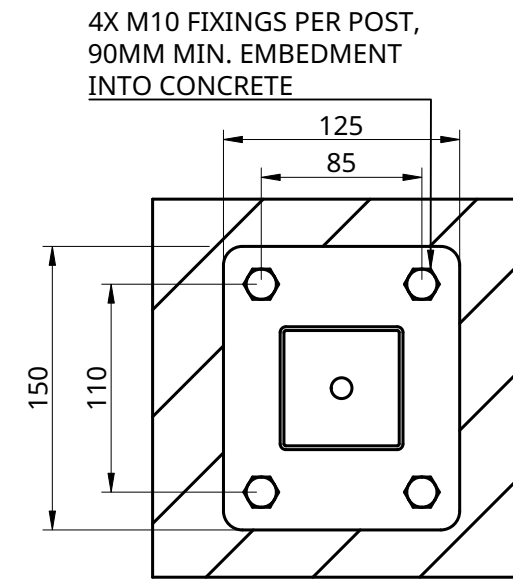

BASEPLATED POST CONNECTION

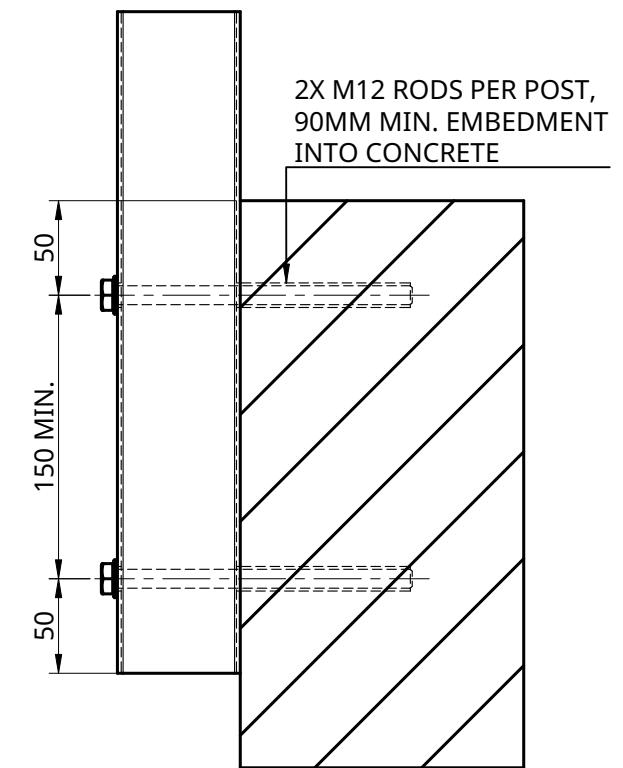

SIDE FIX TO CONCRETE CONNECTION



SIZE:	A3	SCALE:	1:4
DRAWING NO:	ASHD18 - SS	REVISION:	01
DATE ISSUED:	2023-02-21	SHEET:	2 OF 2