



230_{VAC}

BISON25 OTI



ENCODER

INDUSTRIAL USE

control unit with built-in receiver, magnetic encoder and inverter
oil lubricated reductions
IP68 limit switch
personalised release key



up to 2500 kg



CONTROL UNITS:

BISON25 OTI — CP.BISON OTI



Foundation plate with anchor bolts included.
Motor and floor fixing distance
269 mm x 114 mm, no. 4 Ø 12 mm.

230 Vac with inverter

- Three phase 230 Vac geared motor, ventilated for intensive use
- Full metal mechanics and oil lubrication. The type of oil used ensures maximum efficiency even at low temperatures
- The encoder device ensures precision in the gate moving phases
- Casing protective treatment and paint
- The inverter technology allows for more precise adjustment of the gate moving phases, and increased crush prevention security
- Optional built-in FTC.S photocells, available as accessory

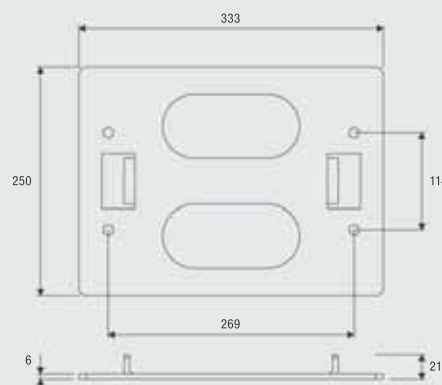
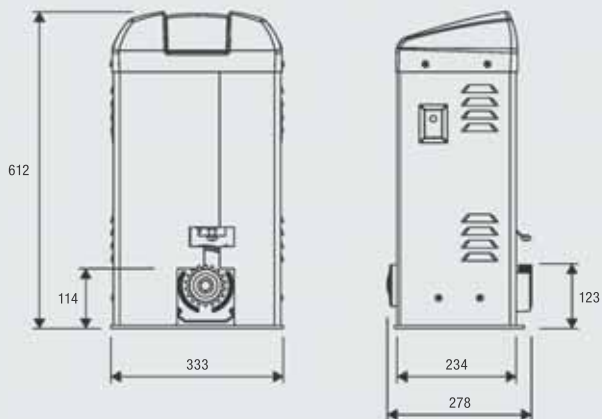



TECHNICAL DATA	BISON25 OTI
Power supply	230 Vac (50-60Hz)
Motor supply	≈ 230 Vac
Max absorbed current	8 A
Max Thrust	2500 N
Max opening speed	19 m/min
Duty cycle	intensive use
Protection level	IP44
Operating temperature	-20°C /+50°C
Lubrication	OIL
Max gate weight	2500 kg
Driving gear for rack	M4 Z18
Weight	41.2 kg